

Automatic transfer switch (ATS)— contactor-based



Contents

Description	Page
Automatic transfer switches	2
Application description	2
Switch types	4
Transition types	4
Contactor construction	5
Automatic transfer switch—open transition	7
Non-automatic transfer switch— open transition	10
Automatic transfer switch—closed transition	13
Wallmount transfer switch logic family	15
Contactor feature list	16
Feature description	19
Glossary	23
Communications	24



Powering Business Worldwide

Automatic transfer switches

Product description

Eaton automatic transfer switches are reliable, rugged, versatile, and compact assemblies for transferring essential loads and electrical distribution systems from one power source to another. Eaton's contactor-based transfer switch is rated 40–1600A and can be supplied in separate enclosures for stand-alone applications or can be supplied as an integral component in the following equipment:

- Magnum™ DS switchgear
- Pow-R-Line™ switchboards
- Motor control centers (MCCs)
- Panelboards

For detailed information on the aforementioned equipment, please see Eaton's 15th edition of the *Consulting Application Guide*.

Note: For information on transfer switch panels, refer to Volume 2—Commercial Distribution, Tab 5, CA08100003E.

Application description

A transfer switch is a critical component of any emergency or standby power system. When power is lost from Source 1 (normal), a transfer switch quickly and safely shifts the load circuit from Source 1 to Source 2 (emergency). This permits critical loads to continue running with minimal or no outage. After power to Source 1 has been restored, the re-transfer process returns the load circuit to Source 1.

Contactor-based transfer switches are available with different operational modes, including:

- Non-automatic
- Automatic

The power-switching operation of transfer switches may be separated into the two key categories of:

- Open transition—break-before-make operation
- Closed transition—make-before-break operation

The three basic components of a transfer switch are:

- Power-switching device to shift the load circuits to and from the power source
- Transfer logic controller to monitor the condition of the power sources and provide the control signals to the power-switching device
- Control power source to supply operational power to the controller and switching device

Typical applications

Eaton automatic transfer switches are designed to be operated in a variety of applications requiring backup power. The most typical applications are shown below with a utility main source and generator backup source in **Figure 1**. **Figure 2** shows a generator normal source and a generator backup source.

Utility-generator

Transfer switches are traditionally applied between a utility and a generator set for emergency and standby power systems.

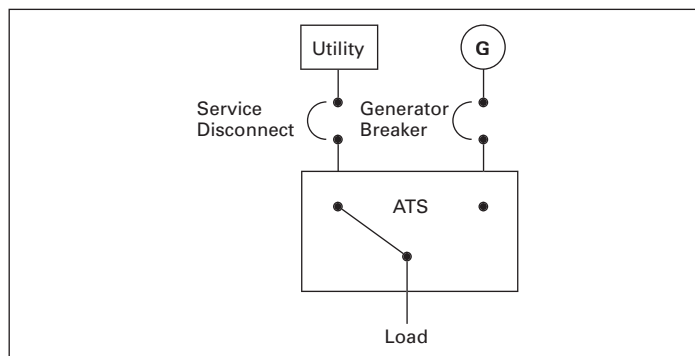

Figure 1. Standard Application Utility-Generator

Generator-generator

Transfer switches are sometimes applied between two generator sets for prime power use (often in remote installations). In such applications, source power is periodically alternated between the generator sets to equally share run time.

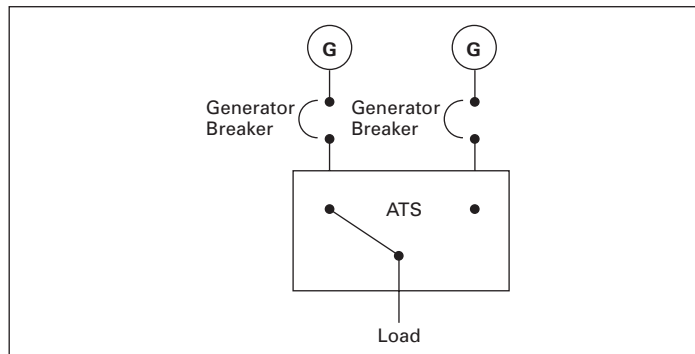

Figure 2. Standard Application Generator-Generator

Table 1. Transfer Switch Standards

Standard	Description
UL 991	UL standards for safety tests for safety-related controls employing solid-state devices
UL 1008	Standard for safety—transfer switch equipment
NEMA® ICS 109.21	Impulse withstand test
IEEE® 472 (ANSI C37.90A)	Ring wave immunity/voltage surge test
EN55011	(CISPR11): Conducted and radiated emissions
EN61000-4-2 Class B	Level 4 ESD immunity test
EN61000-4-3	(ENV50140) radiated RF, electromagnetic field immunity test
EN61000-4-4	Electrical fast transient/burst immunity test
EN61000-4-5	IEEE C62.41: Surge immunity test
EN61000-4-6	(ENV50141) Conducted immunity test
EN61000-4-11	Voltage dips and interruption immunity
FCC Part 15	Conducted/radiated emissions (Class A)
CISPR 11	Conducted/radiated emissions (Class A)
IEC 1000-2	Electrostatic discharge test
IEC 1000-3	Radiated susceptibility tests
IEC 1000-4	Fast transient tests
IEC 1000-5	Surge withstand tests
CSA® conformance	C22.2 No. 178-1978 (reaffirmed 1992)
UL 50/508	Enclosures
NEMA ICS 1	General standards for industrial control systems
NEMA ICS 2	Standards for industrial control devices, controllers, and assemblies
NEMA ICS 6	Enclosures for industrial controls and systems
NEMA ICS 10-1993	AC automatic transfer switches
ANSI C33.76	Enclosures
NEC® 517, 700, 701, and 702	National Electrical Code®
NFPA® 70	National Fire Protection Agency®
NFPA 99	Health care facilities
NFPA 101	Life safety code
NFPA 110	Emergency and standby power systems
EGSA 100S	Standard for transfer switches
CSA C22.2 No. 178-1978	Canadian Standards Association

Table 4. UL 1008 Withstand and Close-On Ratings (kA)

UL 1008 Ampere Rating	Mechanism	480V		600V		600V		Fuse Type	Maximum Fuse Amperes
		Any Breaker	Specific Breaker	Any Breaker	Specific Breaker	Specific Fuse Rating ①			
40, 80, 100	C2	10,000	30,000	10,000	22,000	100,000	RK5	200	
150, 200	C2	10,000	30,000	22,000	35,000	100,000	RK5	400	
225, 260, 400	C2	30,000	50,000	—	—	200,000	RK5	600	
40, 80, 100, 150, 200	C3, C5	30,000	50,000	22,000	35,000	200,000	RK5	400	
225, 260, 400	C3, C5	30,000	50,000	50,000	65,000	200,000	RK5	600	
600, 800, 1000, 1200	C3, C5	50,000	65,000	50,000	65,000	200,000	L, R, J, T	1600	
1600	C3, C5	50,000	65,000	—	—	200,000	L, R, J, T	2000	

① Specific fuse rating for 40–100A, C2 mechanism is 480V only. 1600A is 480V fuse rating only.

UL 1008

All Eaton transfer switches are designed to meet the requirements set forth by UL® 1008; however, all transfer switches are not created equal. You can be assured of safe and reliable operation from all types of transfer switches that Eaton offers.

UL 1008 endurance testing

The importance of specifying a UL 1008 transfer switch can be seen in **Table 1**. When specifying any UL 1008 transfer switch, you can be assured the switch has met and passed the following endurance testing.

Table 2. UL 1008 Endurance Testing

ATS Ampere Rating	Rate of Operation per Minute	With Current	Without Current	Total
0–300	1	6000	—	6000
301–400	1	4000	—	4000
401–800	1	2000	1000	3000
801–1600	0.5	1500	1500	3000

Life expectancy based upon UL 1008 endurance testing

Transfer switch applications typically require a plant exerciser once a week or once a month. **Table 2** demonstrates the life expectancy operating the UL 1008 switch once a week for the life of the switch.

Table 3. Life Expectancy Based Upon UL 1008 Endurance Testing

ATS Ampere Rating	Minimum Operation per Year	Life Expectancy in Years	
		With Current Applied	Without Current Applied
0–300	52	115	115
301–400	52	76	76
401–800	52	38	57
801–1600	52	28	57

Switch types

Non-automatic transfer

This type of transfer is manually initiated, but electrically operated via the solenoid in a contactor-based design.

Automatic transfer

This type of transfer takes place automatically per the programmable settings in the ATS controller. The ATS controller senses source availability and when the programmed conditions are met, initiates a command to start the transfer including the generator start command (when transferring from a utility to a generator source). An automatic transfer switch can be configured to perform a utility-to-utility transfer or a generator-to-generator transfer (provided the ATS controller has this capability).

Transition types

Open transition

This is a “break-before-make” transfer. There is a definite break in power as the load is taken off one source and connected to the other source.

Open in-phase transition

This is a “break-before-make” transfer. There is a definite break in power as the load is taken off one source and connected to the other source. The ATS controller allows the transfer only when the phase difference between the two sources is near zero. The transfer switch is closed on Source 1 or closed on Source 2.

Delayed transition with time delay neutral

This is a “break-before-make” or open transition that also has a “center off” or neutral position with a programmable time delay setting for the neutral position. The transfer switch is either closed on Source 1, closed on Source 2, or in a center off, neutral position (not closed on either source).

Delayed transition with load voltage decay

This is a delayed transition with the optional feature to delay in the neutral position to point where the load voltage decays to a programmable voltage level. When the load voltage level reaches the programmable set point, the transfer from the neutral position initiates.

Open in-phase transition with default to delayed transition

This is a “break-before-make” transfer. The ATS controller will attempt to transfer in-phase between two live sources. In the event that an in-phase transfer cannot be achieved, the controller will continue on to transfer delayed transition. A delayed transition will always be performed in a power outage situation.

Closed transition

This is a “make-before-break” transfer. Both sources are connected to the load for less than 100 ms before the break occurs. The two power sources have to be in synchronism and be good sources for the transfer to take place. These programmable settings for relative phase angle difference, frequency, and voltage difference are made in the ATS controller.

Table 5. Transition Types

Transition	Contactor-Based		
	Two-Position	Three-Position	
	C2	C3	C5
Open	Yes	Yes	Yes
Open in-phase	Yes	No	No
Open in-phase/time delay neutral	No	No	Yes
Delay—time delay neutral	No	Yes	Yes
Delay—load voltage decay	No	Yes	No
Closed	No	Yes	Yes

Contactor construction

The Eaton open transition contactor transfer switch is available with a two-position or a three-position mechanism. Both contactor types have two cross shafts, one for Source 1 (S1) contacts and one for Source 2 (S2) contacts. The mechanism can be operated both electrically and mechanically (de-energized).

Contact composition

Eaton uses silver composition contacts designed to meet the stringent requirements of UL 1008. All Eaton contactors are designed so that the contacts can be visually inspected without major disassembly and are protected by arcing contacts.

Arc mitigation

All Eaton contactors include arc chutes for each switched pole. The arc chute is used to stretch the arcing that is created when contacts open, until the voltage can no longer be sustained to keep it going. Contactors rated 400A and below include stationary arc runner contacts designed to magnetically draw an arc into the plates of arc chute. Contactors rated 600A and above include separate moveable arcing contacts that will make first and break last.

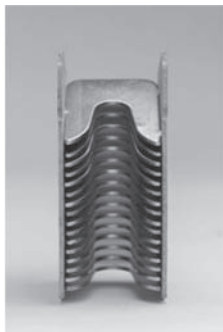

400A Arc Chute

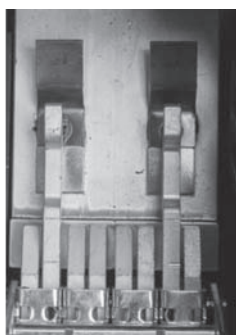

Separate Arcing Contacts Extend Beyond
the Main Current-Carrying Contacts

Neutral switching—fully rated fourth pole (switched neutral)

Eaton provides a fully rated switched neutral or fourth pole meaning that the fourth pole has withstand, interrupt, and closing ratings identical to the power contacts. The neutral pole is operated on a common shaft with the power contacts, thereby ensuring simultaneous opening and closing of the switched neutral. Eaton's fully rated fourth pole eliminates typical problems with a three-pole overlapping neutral:

- Eliminates nuisance ground trips at the main due to circulating zero sequence harmonic current between sources
- Reduction in ground current due to isolated single ground point lowers arc flash levels and reduces generator damage
- Eliminates potential for faults to propagate across overlapping neutral. Fully rated fourth pole will handle as a normal operation
- Does not generate voltages that exceed normal phase voltage

Note: For more detail, reference Eaton White Paper *Three- and Four-Pole Transfer Switching Characteristics*, IA08700002E.

Two-position contactor construction

A two-position contactor mechanism includes a Source 1 and Source 2 position. The mechanism used to operate the two-position contactor is a momentarily energized solenoid, consisting of a stationary core and a moving core that are magnetically driven by an electrical coil. When switching from Source 1 to Source 2 or Source 2 to Source 1, the mechanism will only allow a break-before-make operation (open transition). The mechanism is inherently interlocked so that the device cannot be closed on Source 1 and Source 2 at the same time under any condition. This is a fast transfer mechanism with transfer time of less than 150 ms. A two-position transfer switch is designed to transfer with in-phase transition enabled for inductive loads.

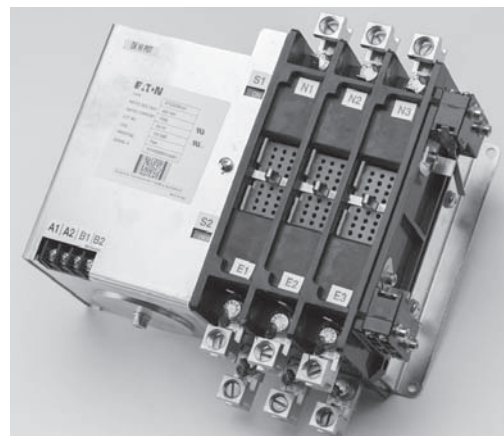

100A Two-Position Contactor Construction

Three-position contactor construction—delayed transition and in-phase default to delayed transition

A three-position contactor mechanism includes a Source 1, Source 2, and OFF position. The three-position contactor uses a solenoid-based operating mechanism with three solenoids. The solenoids are used to trip, select the source being transferred to, and close the moving contacts. The mechanism is inherently interlocked so that the device cannot be closed on Source 1 and Source 2 at the same time under any condition. A three-position mechanism can be used for delayed and/or in-phase transition. Transfer time is less than 150 ms provided that no time delayed in neutral is set.

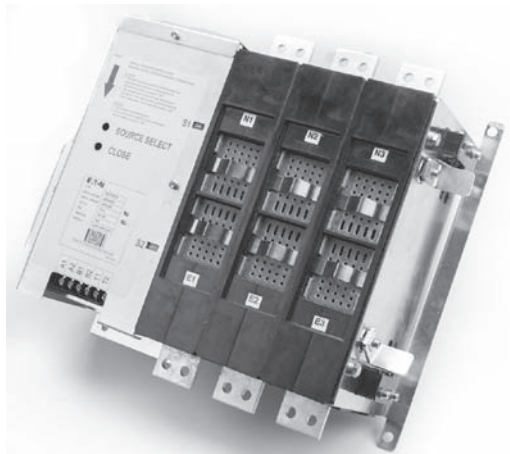

400A Three-Position Contactor Construction

Three-position contactor construction—closed transition

The closed transition contactor construction is similar to a three-position open transition contactor; however, it does not include mechanical interlocks. The closed transition contactor operates in a make-before-break fashion and in conjunction with the transfer switch logic, will not remain paralleled greater than 100 ms. This design includes a parallel limit timer, adjustable for 0.01 to 0.5 seconds, that will signal an upstream breaker to trip in the unlikely event the sources remain paralleled.

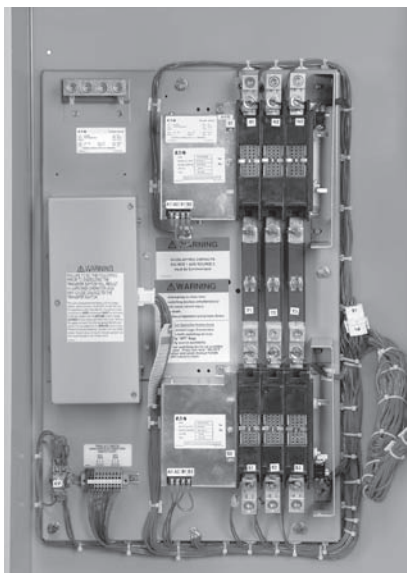

100A Closed Transition Contactor Construction

Solid neutral connection

Transfer switches applied in a single-phase, three-wire system or a three-phase, four-wire system include a 100% rated solid neutral connection. A neutral connection is not included in transfer switches supplied as single-phase, two-wire or three-phase, three-wire.

Note: Contact factory for neutrals rated greater than 100%.

Grounding provisions

Every contactor transfer switch is provided with a copper ground bar for customer ground connections.



Grounding Provisions

Automatic transfer switch—open transition

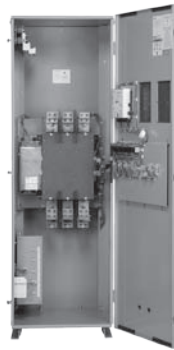

ATC-300+ Controller

Product description

Eaton’s automatic transfer switch (ATS) provides unmatched performance, reliability, and versatility for critical standby power applications. All switches can be equipped with the ATC-100, ATC-300+, and ATC-800 controllers to match any application need. Each controller offers rock-solid monitoring, status reporting, and transfer control operation.

Superior design and robust construction make Eaton’s transfer switch the industry benchmark for critical and distributed power systems.

Electrical ratings

- Ratings 40, 80, 100, 150, 200, 225, 260, 400, 600, 800, 1000, 1200, and 1600A
- Two-, three-, or four-pole
- Up to 600 Vac, 50/60 Hz
- NEMA® 1, 12, 3R, 4X, open
- UL® 1008 Listed
- CSA® C22.2 No. 178 Certified

Industrial design highlights

- Double-throw, mechanically interlocked transfer mechanism, preventing connection of both sources
- Field-selectable multi-tap transformer panel permits operation on a wide range of system voltages
- Methods of transfer include: open in-phase transition, time delay in neutral transition, or in-phase with a default to time delay in neutral transfer

Standard features (ATC-300+)

- Source present relays:
 - Source 1 present 2NO and 2NC
 - Source 2 present 2NO and 2NC
- Switch position indication contacts:
 - Source 1 position 1NO and 1NC
 - Source 2 position 1NO and 1NC
- Source 1 and Source 2 sensing:
 - Undervoltage/underfrequency
 - Overvoltage/overfrequency
 - Three-phase rotation protection
 - Three-phase voltage unbalance
- Pre-transfer signal contacts 1NO/1NC (with three-position mechanism)
- Go to Emergency (Source 2)
- Seven field-programmable time delays
- LCD-based display for programming, system diagnostics, and Help message display
- Mimic diagram with source available and connected LED indication
- Time-stamped history log
- System test pushbutton
- Programmable plant exerciser—OFF, daily, 7-, 14-, 28-day interval selectable run time 0–600 minutes no load/load with fail-safe

Optional features

- Available surge suppression device for power/controller, engine start circuit, phone, and cable connections
- Space heater with thermostat
- Eaton IQ and Power Xpert® Series metering
- Stainless steel cover for controller
- Open in-phase transition, time delay neutral, or in-phase with a default to time delay neutral transfer
- ATC-100 and ATC-800 controllers available
- Modbus® RTU via RS-485
- Source 2 inhibit
- Manual re-transfer to normal
- Remote annunciator with control
- Ethernet communication (PXG 400 Gateway)

Table 6. Automatic Transfer Switch Catalog Numbering System

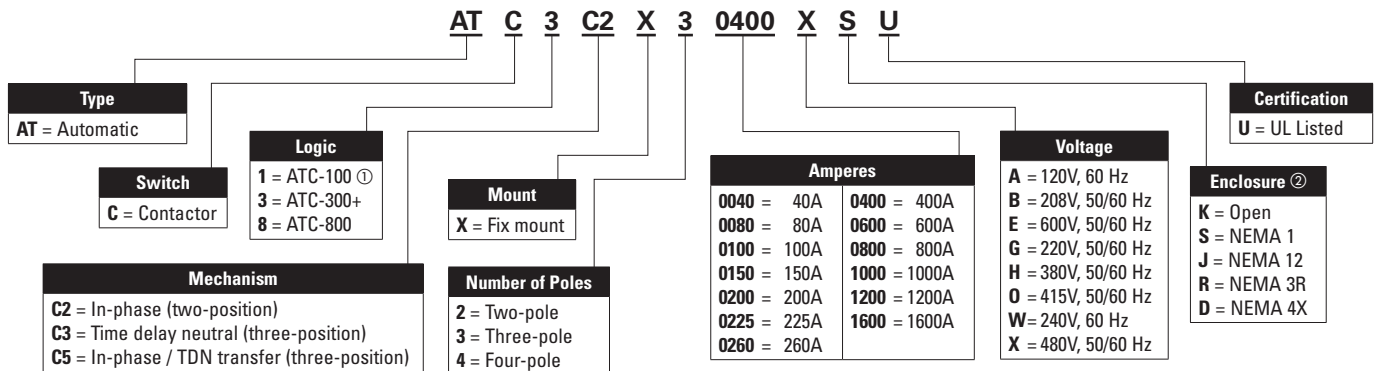

① ATC-100 applies to 400A and below.
② NEMA 12 and 4X, 40–1200A only.

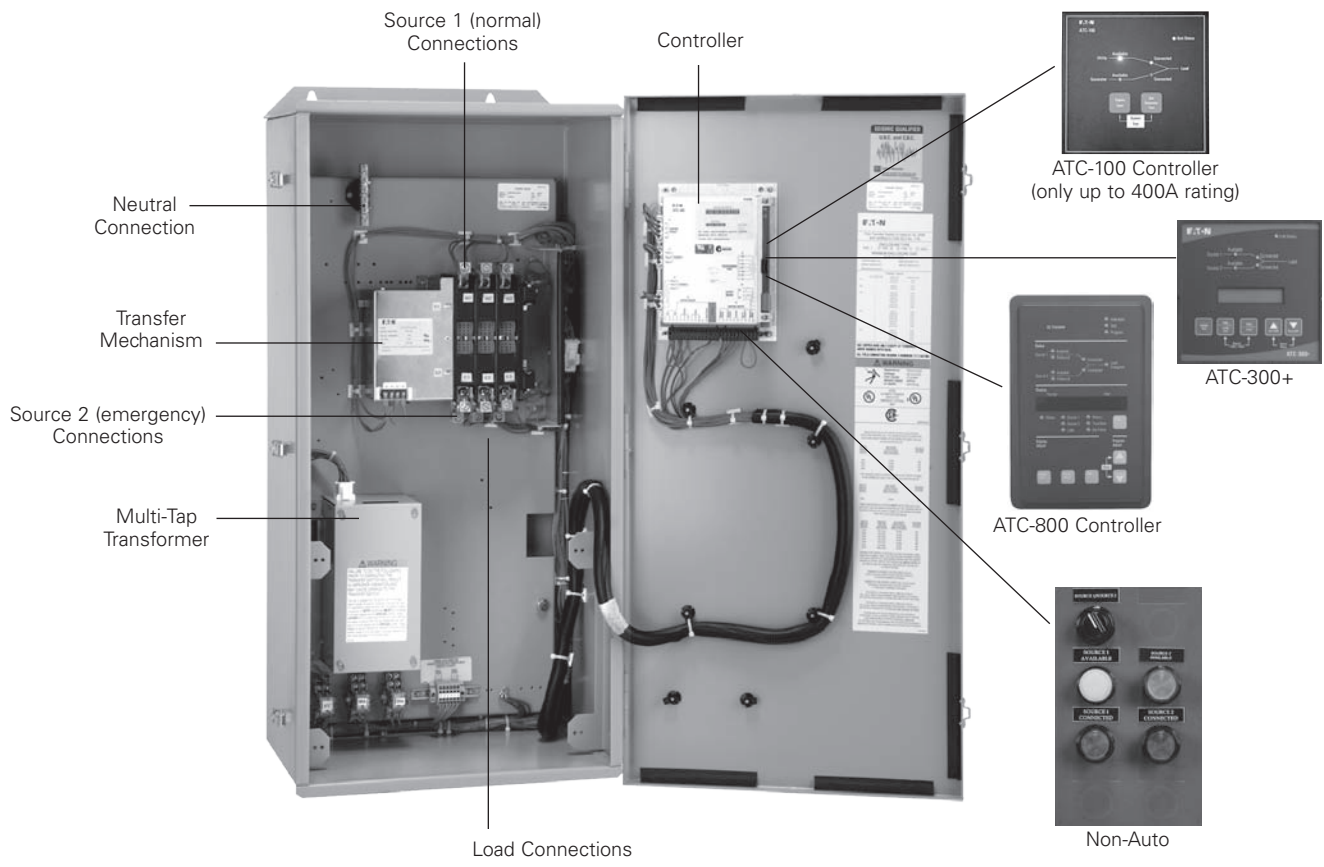

Basic Components of the 100–400A ATS

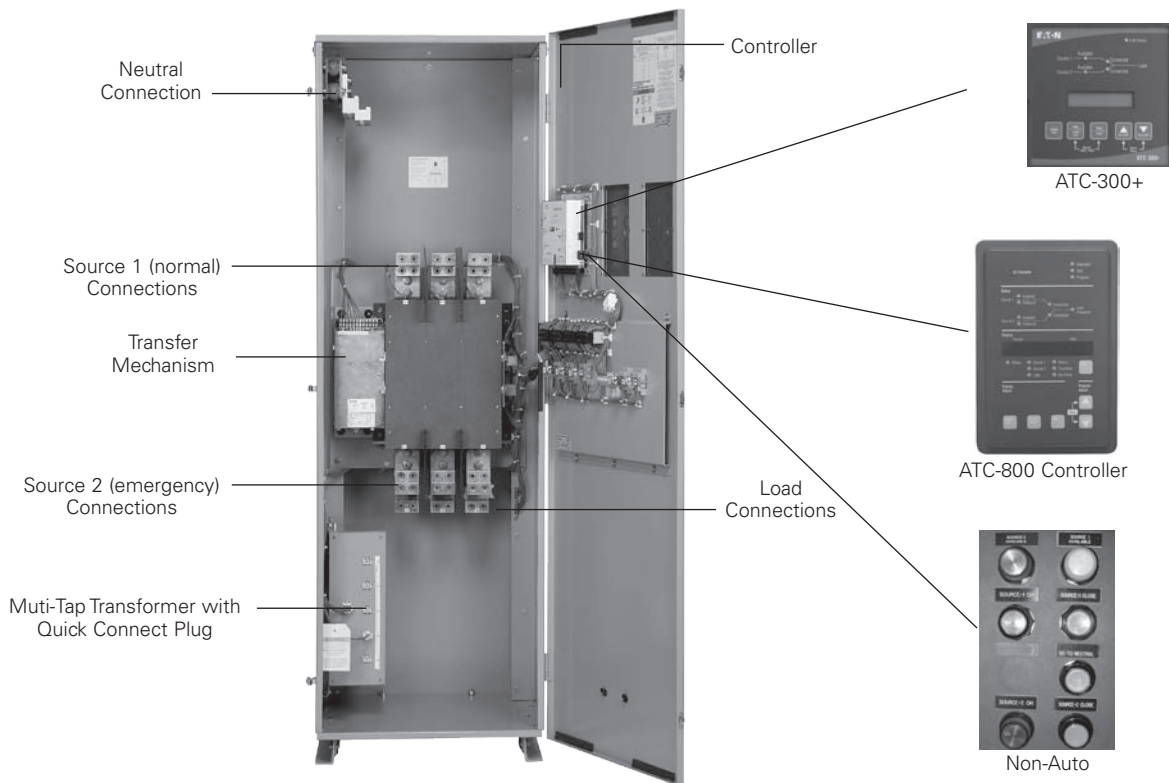

Basic Components of the 600–1600A ATS

Multi-tap voltage selector (quick connect)



Multi-Tap Voltage Selector

The industry-exclusive Eaton multi-tap system voltage selector allows our transfer switch to be applied on most system voltages just by proper insertion of the selector plug. Available in two configurations: worldwide multi-tap with 600, 480, 415, 380, 240, 220, and 208 Vac, single- and three-phase, 50 and 60 Hz taps; and North American multi-tap with 600, 480, 240, 208, and 120 Vac, single- and three-phase, 60 Hz taps.

The quick-connect multi-tap transformer is used on the 600–1600A ratings.

Multi-tap transformer



Transformer Panel
Allows for Easy Field
Changes to Voltage
Configurations

Transformer Panel Opened

The North American multi-tap transformer comes with 600, 480, 240, 208, and 120 Vac, single- and three-phase, and 60 Hz taps that are all field selectable. Simply remove the steel cover and move the appropriate blue flag terminal to the desired voltage. All switches are shipped with the blue flag in the 600V position.

This multi-tap transformer is used on the ratings up to 400A.

Ease of maintenance

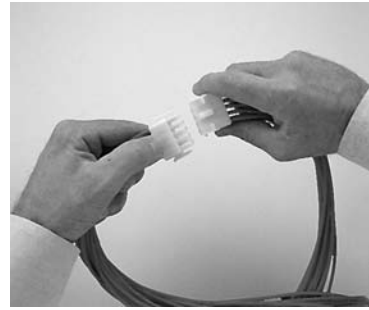

Logic Disconnect Plugs

Keyed quick-disconnect plugs are provided for easy and complete isolation of the control circuitry.

Maintenance can be performed on the logic independent from the power sections.

Controls and wiring

All control relays and industrial-grade relays are totally encapsulated to minimize exposure to dust and dirt that can adversely affect logic control functions.

- All Eaton lugs are 90°C rated
- All control wire in the Eaton transfer switch is #16 AWG, type XLPE with a 125°C temperature rating

Manual operation

The contactor-based automatic transfer switches can be manually operated by utilizing a tool supplied with the switch. Always make sure that the Source 1 power and Source 2 power are off before making the manual transfer.



40–400A Contactor ATS



600–1600A Contactor ATS

Non-automatic transfer switch— open transition

General description

A non-automatic transfer switch functions as a manually initiated and electrically operated device. Door-mounted source availability and connected lights used in conjunction with pushbuttons and selector switch controls permit the main contacts to be opened and closed electrically. There is, however, no transfer intelligence associated with this design. Transfer power is derived from any available source and it is possible to transfer to a dead source if desired.

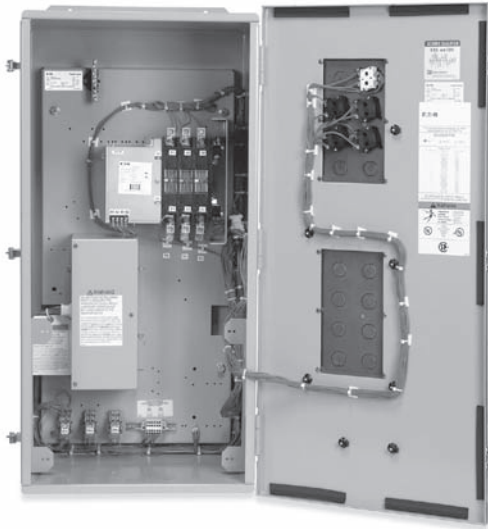

Two-Position Non-Automatic Transfer Switch

Design features

- Double-throw, mechanically interlocked transfer mechanism, preventing connection of both sources
- Field-selectable multi-tap transformer panel permits operation on a wide range of system voltages
- Method of transfer is open transition
- 30 mm Source 1 and Source 2 available indication
- 30 mm Source 1 and Source 2 connected indication
- Manually initiated transfer controls
- Source present relays:
 - Source 1 present 2NO and 2NC
 - Source 2 present 2NO and 2NC
- Switch position indication contacts:
 - Source 1 position 1NO and 1NC
 - Source 2 position 1NO and 1NC

Eaton's non-automatic contactor transfer switches are built using standard open transition construction (reference dimensions tables).

For applications that may have a future need to upgrade to automatic transition, it is best to apply an ATC-300+ or ATC-800 controller with an automatic/manual sector switch (option 29g).

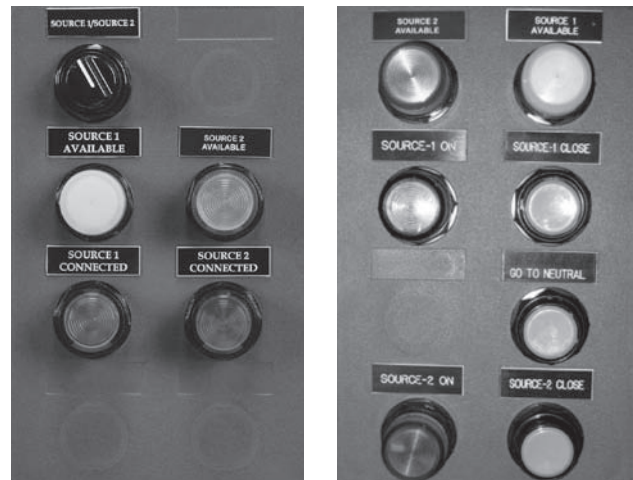

Two-Position

Three-Position

Non-Automatic Device Panels

Table 7. Non-Automatic Transfer Switch Catalog Numbering System

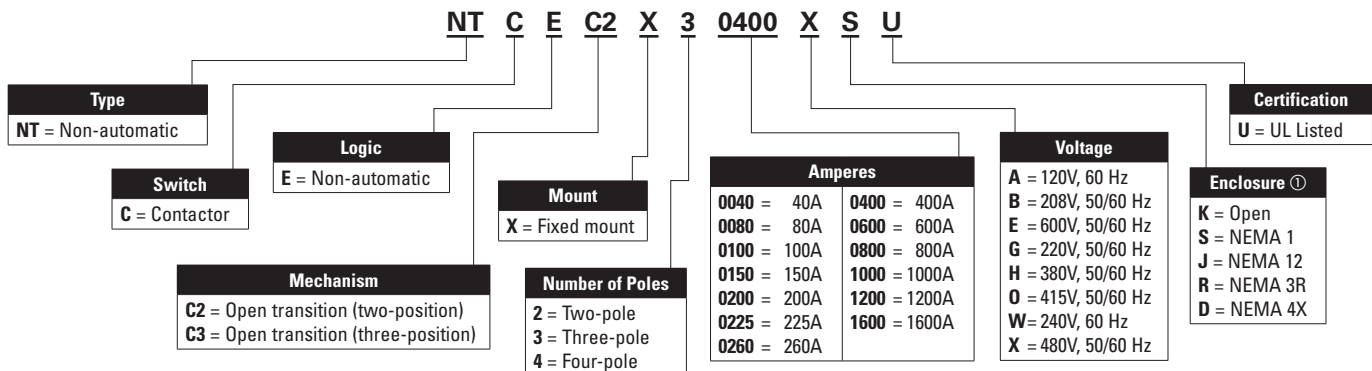

① NEMA 12 and 4X, 40–1200A only.

Dimensions—approximate dimensions in inches (mm)

Table 8. Contactor-Based Transfer Switch 40–1200A—Dimensions in Inches (mm) and Approximate Shipping in Lbs (kg)

Ampere Rating	Enclosure	A (Height)	B (Width)	C (Depth)	G (Horizontal)	H (Vertical)	Load Side, Normal and Standby Source	Neutral Connection	Weight Lbs (kg)
40–100 at 480V ①	N1, N12, N3R	38.68 (982.5)	18.31 (465.1)	13.34 (338.8)	10.25 (260.4)	37.38 (949.5)	(1) #14–2/0	(3) #14–1/0	156 (71)
	N4X	37.50 (952.5)	17.50 (444.5)	14.34 (364.2)	11.50 (292.1)	36.25 (920.8)	(1) #14–2/0	(3) #14–1/0	156 (71)
40–100 at 600V ①	N1, N12, N3R	38.68 (982.5)	18.31 (465.1)	13.34 (338.8)	10.25 (260.4)	37.38 (949.5)	(1) #14–2/0	(3) #14–1/0	164 (74)
	N4X	37.50 (952.5)	17.50 (444.5)	14.34 (364.2)	11.50 (292.1)	36.25 (920.8)	(1) #14–2/0	(3) #14–1/0	164 (74)
150–200 at 480V ①	N1, N12, N3R	38.68 (982.5)	18.31 (465.1)	13.34 (338.8)	10.25 (260.4)	37.38 (949.5)	(1) #6–250 kcmil	(3) 1/0–250 kcmil	164 (74)
	N4X	37.50 (952.5)	17.50 (444.5)	14.34 (364.2)	11.50 (292.1)	36.25 (920.8)	(1) #6–250 kcmil	(3) 1/0–250 kcmil	164 (74)
150–200 at 600V ①	N1, N12, N3R	52.00 (1321.0)	19.81 (503.0)	16.75 (425.0)	13.00 (330.0)	47.84 (1215.1)	(1) #6–250 kcmil	(3) 1/0–250 kcmil	260 (118)
	N4X	52.00 (1321.0)	21.00 (533.0)	16.75 (425.0)	15.00 (381.0)	50.75 (1289.0)	(1) #6–250 kcmil	(3) 1/0–250 kcmil	260 (118)
225–400 at 480V ①	N1, N12, N3R	52.00 (1321.0)	19.81 (503.0)	16.75 (425.0)	13.00 (330.0)	47.84 (1215.1)	(2) 3/0–250 kcmil or (1) 3/0–600 kcmil	(6) 250–500 kcmil	260 (118)
	N4X	52.00 (1321.0)	21.00 (533.0)	16.75 (425.0)	15.00 (381.0)	50.75 (1289.0)	(2) 3/0–250 kcmil or (1) 3/0–600 kcmil	(6) 250–500 kcmil	260 (118)
225–1200 at 600V ②	N1, N3R	79.41 (2017.0)	29.19 (741.4)	22.46 (570.5)	—	—	(4) 1/0–750 kcmil	(12) 1/0–750 kcmil	600 (272) 3-pole 650 (295) 4-pole
	N12, N4X	84.75 (2152.7)	29.00 (737.0) 3-pole 29.00 (737.0) 4-pole	24.26 (616.0)	—	—	(4) 1/0–750 kcmil	(12) 1/0–750 kcmil	700 (318) 750 (340)
600–1200 at 480V ②	N1, N3R	79.41 (2017.0)	25.25 (641.4) 3-pole 29.19 (741.4) 4-pole	22.46 (570.5)	—	—	(4) 1/0–750 kcmil	(12) 1/0–750 kcmil	600 (272) 3-pole 650 (295) 4-pole
	N12, N4X	84.75 (2152.7)	29.00 (737.0) 3-pole 29.00 (737.0) 4-pole	24.26 (616.0)	—	—	(4) 1/0–750 kcmil	(12) 1/0–750 kcmil	700 (318) 750 (340)

① Wallmount.

② Floorstanding and wall secured—height dimension includes the bottom bracket.

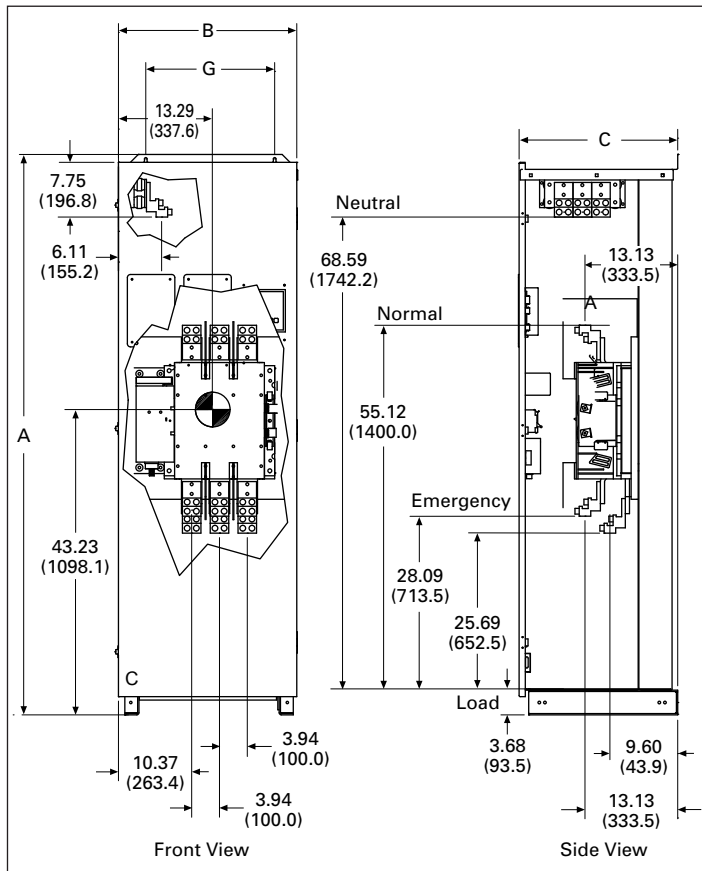

Figure 3. Automatic, Non-Automatic 600–1200A Open Transition Outline NEMA 1 and NEMA 3R

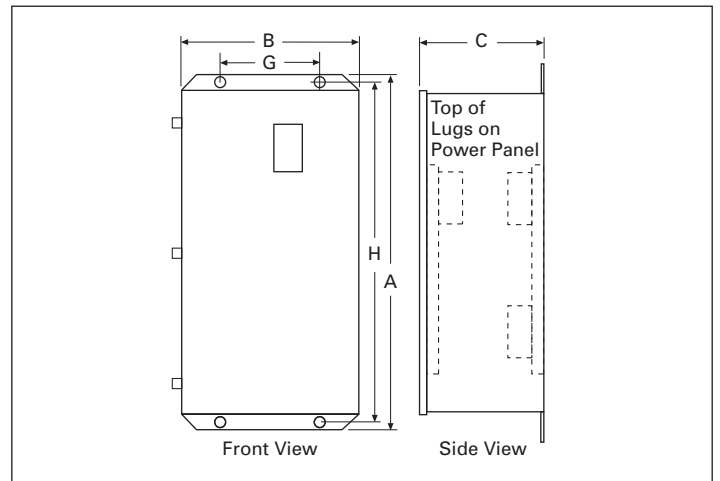

Figure 4. Automatic, Non-Automatic Open Transition up to 400A Wallmount Outline NEMA 1 and NEMA 3R

Table 9. 1600A Transfer Switch

Ampere Rating	Enclosure	A (Height)	B (Width)	C (Depth)	G (Horizontal)	H (Vertical)	Load Side, Normal and Standby Source	Neutral Connection	Weight Lbs (kg)
1600A at 480V ①	N1	90.00 (2286.0)	40.00 (1016.0)	29.00 (736.6)	—	—	(4) 1/0–750 kcmil	(12) 1/0–750 kcmil	730 (331) 3-pole
	N3R	90.72 (2304.3)	40.35 (1024.9)	47.59 (1208.8)	—	—	(4) 1/0–750 kcmil	(12) 1/0–750 kcmil	780 (354) 3-pole 830 (377) 4-pole

① Freestanding



1600A Open Transition NEMA 1 Contactor

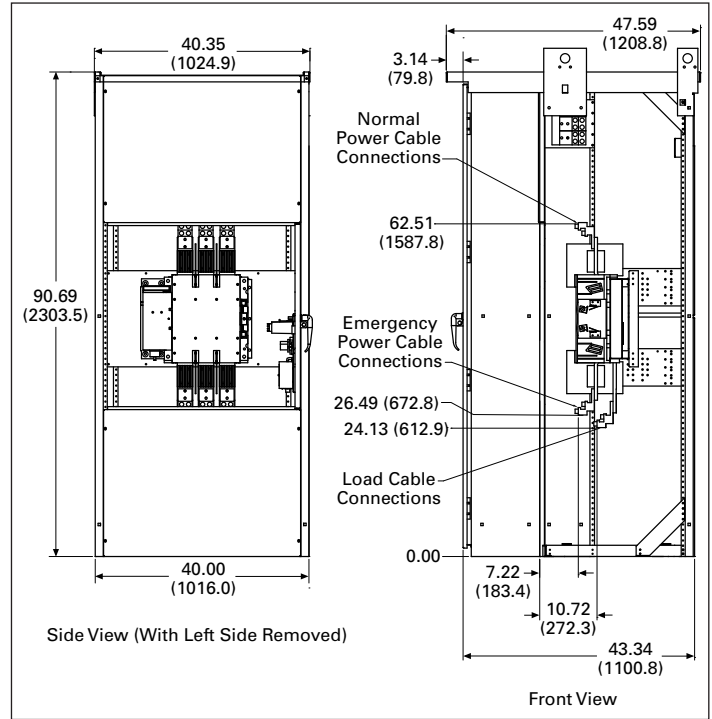

Figure 6. Automatic, Non-Automatic Open Transition NEMA 3R Enclosure

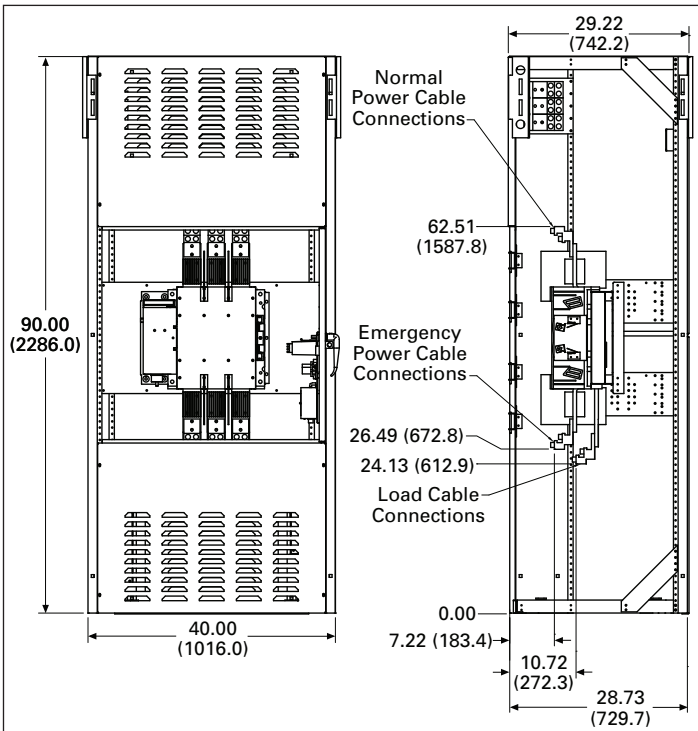

Figure 5. Automatic, Non-Automatic Open Transition NEMA 1 Enclosure

Automatic transfer switch—closed transition



Contactor-Based ATS with ATC-800 Controller

General description

Eaton's closed transition contactor-based automatic transfer switch (CTC8) is designed to avoid intentional interruption of power when both sources of power are available by momentarily paralleling both sources.

The ATC-800 is a comprehensive, multi-function, microprocessor-based controller, offering extensive monitoring, status reporting, and transfer control operation.

The make-before-break contact sequence coupled with Eaton's ATC-800 provides a transfer switch that is useful in critical standby power applications available from 40 to 1200A.

Application description

A transfer switch designed for closed transition has make-before-break contacts that require the normal and alternate sources to be synchronized. The source contacts on Eaton's CTC8 will parallel for 100 ms or less. The ATC-800 provides all-phase undervoltage, underfrequency, overvoltage, and overfrequency protection as a standard. Consult with the local utility company for permission and to verify the protection requirements as each utility may have different rules regarding closed transition applications. Protective relays may be available as an option upon request.

Closed transition controls

The CTC8 accomplishes the closed transition transfer by monitoring the voltage and frequency set point conditions of both power sources. Once the set point conditions are met, the ATC-800 controller will start the closed transition synchronization timer (TSCT). The TSCT is adjustable from 1 to 60 minutes in duration. This is the time during which the ATC-800 controller will monitor the phase angles to anticipate when they will be within 8 electrical degrees. The closed transition scheme is anticipatory, allowing the close contacts signal to be initiated before the sources are exactly in phase. If the TSCT times out and the transfer switch has not reached synchronization, the transfer switch will remain connected to the current power source, and a failure to transfer alarm will be displayed.

The transfer switch can also be equipped with an optional open transition transfer method for situations where synchronization is not possible, but a transfer is required. One of the following transition features can be selected:

- Closed transition only
- Closed transition with default to load voltage decay
- Closed transition with default to time delay neutral

Features

Standard features—with ATC-800 controller

- Auxiliary relay contacts:
 - Source 1 present 1NO and 1NC
 - Source 2 present 1NO and 1NC
- Switch position indication contacts:
 - Source 1 position 1NO and 1NC
 - Source 2 position 1NO and 1NC
- Source 1 and Source 2 sensing:
 - Undervoltage/underfrequency
 - Overvoltage/overfrequency
- Go to emergency (Source 2)
- Seven field-programmable time delays
- LCD-based display for programming, system diagnostics, and Help message display
- Mimic diagram with source available and connected LED indication
- Time-stamped history log
- System TEST pushbutton
- Programmable plant exerciser—OFF, daily, 7-day interval selectable run time 0–600 minutes no load/load with fail-safe
- Multi-tap transformer

Optional features

- Available surge suppression device for power/controller, engine start circuit, phone, and cable connections
- Space heater with thermostat
- IQ 100/200 Series
- Power Xpert 2000 Series metering
- Steel cover for controller
- Three-phase rotation protection
- Three-phase voltage unbalance
- Pretransfer signal contacts 1NO/1NC (with three-position mechanism)

Commercial design highlights

- UL 1008 front access
- High withstand and closing ratings
- Compact design

Table 10. Automatic Transfer Switch Catalog Numbering System

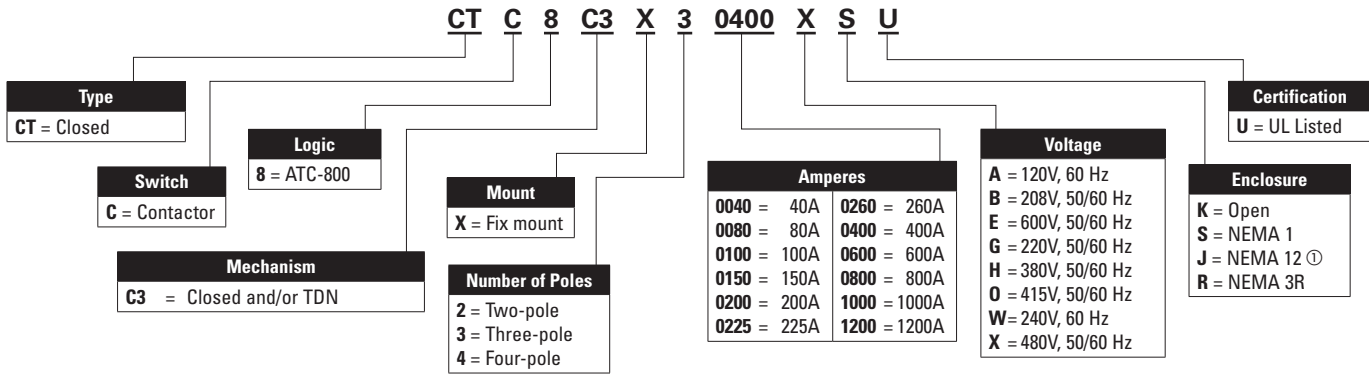

① N12 available 40–400A only.

Dimensions—approximate dimensions in inches (mm)

Table 11. Contactor-Based Transfer Switch 40–1200A Closed Transition (See Figure 7 and Figure 8)

Ampere Rating	Enclosure			Bolt Pattern		Standard Terminals		
	A (Height)	B (Width)	C (Depth)	G (Horizontal)	H (Vertical)	Load Side, Normal and Standby Source	Neutral Connection	Weight in Lbs (kg)
40–100 at 480V	52.74 (1339.6)	25.00 (635.0)	17.18 (436.4)	10.25 (260.4)	37.38 (949.5)	(1) #14–2/0	(3) #14–2/0	190 (86)
40–100 at 600V	52.74 (1339.6)	25.00 (635.0)	17.18 (436.4)	10.25 (260.4)	37.38 (949.5)	(1) #6–250 kcmil	(3) #14–1/0	210 (95)
150–200 at 480V	52.74 (1339.6)	25.00 (635.0)	17.18 (436.4)	10.25 (260.4)	37.38 (949.5)	(1) #6–250 kcmil	(3) 1/0–250 kcmil	210 (95)
150–200 at 600V ①	71.02 (1803.9)	31.11 (790.2)	14.72 (373.9)	13.00 (330.2)	47.84 (1215.1)	(2) 3/0–250 kcmil	(6) 250–500 kcmil	420 (191)
225–400 at 480V	71.02 (1803.9)	31.11 (790.2)	14.72 (373.9)	13.00 (330.2)	47.84 (1215.1)	(2) 3/0–250 kcmil	(6) 250–500 kcmil	420 (191)
225–1200 at 600V ①	90.00 (2286.0)	46.00 (1168.4)	32.00 (812.8)	—	—	(4) 1/0–750 Cu/Al	(12) 1/0–750 kcmil	800 (363)
600–1200 at 480V ①	90.00 (2286.0)	46.00 (1168.4)	32.00 (812.8)	—	—	(4) 1/0–750 Cu/Al	(12) 1/0–750 kcmil	800 (363)

① For NEMA 3R, add 14.60 inches (370.8 mm) to depth.

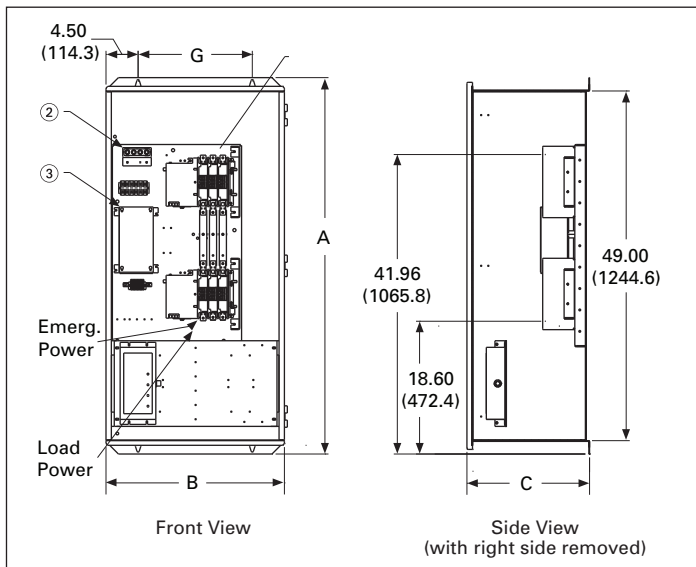

Figure 7. Automatic Up to 400A – Wallmount

- ① For switched neutral applications, connect to terminals marked NN, EN, and LN. Neutral assembly will not be provided.
- ② Transformer pack is not included with 240/120V, single-phase or 208/120V, three-phase systems.

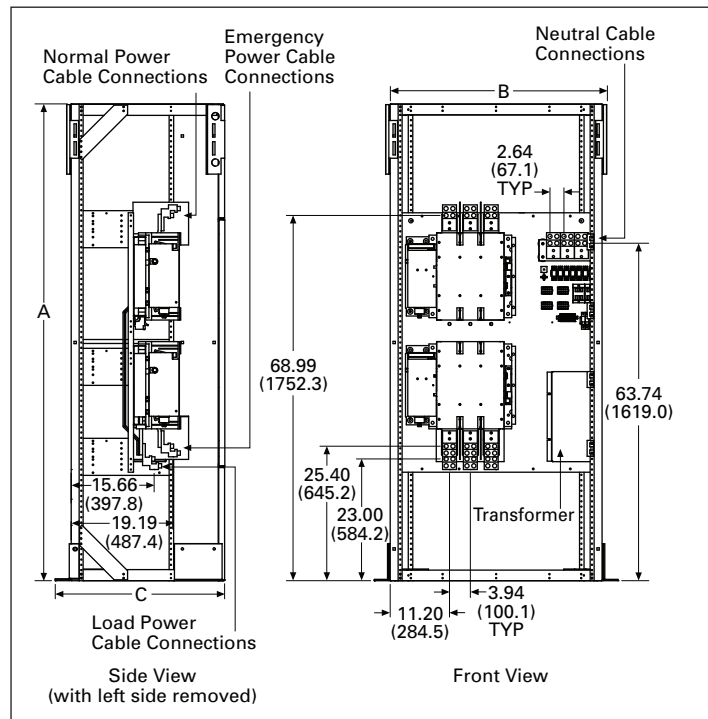

Figure 8. Automatic 600–1200A

Wallmount transfer switch logic family

Eaton is the industry leader in transfer switch control technology and offers a full line of automatic transfer controllers. With the basic-level ATC-100, the advanced-level ATC-300+, and the premium level ATC-800, the Eaton family of controllers is ready to meet the requirements of any system.

Table 12. ATC Controller Selection Chart

Description	ATC-100	ATC-300+	ATC-800
System application voltage	120/240V, 208V single-phase	Up to 600 Vac	Up to 600 Vac
Voltage specifications			
Voltage measurements of	Source 1 and 2	Source 1 and 2— VAB, VBC, and VCA	Source 1, 2, and Load—VAB, VBC, and VCA
Voltage measurement range	120–240 Vac	0–790 Vac rms	0–790 Vac rms
Frequency specifications			
Frequency measurements of	Source 2	Source 1 and 2	Source 1 and 2
Frequency measurement range	50–60 Hz	40–70 Hz	40–80 Hz
Front panel indication			
Mimic diagram with LED indication	Unit status; Source 1 and 2 available and connected (5 total)	Unit status; Source 1 and 2 available and connected (5 total)	Automatic, test, and program mode; Source 1 and 2 available, connected, and preferred; load energized (10 total)
Main display	—	LCD-based display	LED display
Display language	—	English, French	English
Communications capable	—	Modbus®-485	Modbus-485/INCOM
Enclosure compatibility	NEMA 1 and 3R	NEMA 1, 12, 3R, and 4X UV-resistant faceplate	NEMA 1, 12, 3R, and 4X UV-resistant faceplate
Operating environmental range	Operation –20°C to +70°C, Storage +30°C to +85°C, Humidity 0%–95% Relative (noncondensing)	Operation –20°C to +70°C, Storage +30°C to +85°C, Humidity 0%–95% Relative (noncondensing)	Operation –20°C to +70°C, Storage +30°C to +85°C, Humidity 0%–95% Relative (noncondensing)
Programming selections			
Time delay normal to emergency	3 seconds—fixed	0–1800 seconds	0–1800 seconds
Time delay emergency to normal	7 minutes—fixed	0–1800 seconds	0–1800 seconds
Time delay engine cooldown	5 minutes—fixed	0–1800 seconds	0–1800 seconds
Time delay engine start	10 seconds—fixed	0–120 seconds	0–120 seconds
Time delay neutral	—	0–120 seconds	0–120 seconds or based on load Voltage decay of 2%–30% of nominal
Time delay Source 2 (emergency) fail	—	0–6 seconds	0–6 seconds
Time delay voltage unbalance	—	10–30 seconds	—
Voltage unbalance	—	5%–20% (DO) Dropout –2% to 3% (PU)	Optional with external relay
Phase reversal	—	Disabled, ABC, CBA	Optional with external relay
In phase	—	Enabled or disabled	Enabled or disabled
Load sequencing	—	N/A	Up to 10 devices (via sub-network)
Pre-transfer signal (Form C contact)	—	1–120 seconds	0–120 seconds (up to 10 devices via sub-network)
Plant exerciser	Selectable day, 7-day interval, 15-minute run time, no load	Selectable—disabled, daily or 0–600 minutes, load or no load 7-, 14-, 28-day intervals	Selectable—disabled or 7-day interval, 0–600 minutes, load or no load
Preferred source selection	—	—	Source 1 or 2 or none
Commitment to transfer in TDNE	—	—	Enabled or disabled
Re-transfer mode	—	Automatic or manual	Automatic or manual
Auto Daylight Saving Time adjustment	—	Enabled or disabled	—
System selection	Utility/generator or dual utility	Utility/generator or dual utility	Utility/generator or dual utility or dual generator
Additional information	PA01600002E	TD01602006E	TD.15A.05.T.E

Note: Features are order specific. Not all features are supplied as standard.

Contactors feature list

Feature	Device Type									
	ATC1	ATC3			ATC8			NTCE		CTC8
	C2	C2	C3	C5	C2	C3	C5	C2	C3	C3
Timers										
1	Time Delay Normal to Emer (TDNE) Fixed 2 sec or 15 sec	S	—	—	—	—	—	—	—	—
1A	Adjustable 0–1800 sec	—	S	S	S	S	S	S	—	S
2	Time Delay Engine Start (TDES) Fixed 3 sec	S	—	—	—	—	—	—	—	—
2A	Adjustable 0–120 sec	—	S	S	S	S	S	S	—	S
3	Time Delay Emergency to Normal (TDEN) Fixed 5 min	S	—	—	—	—	—	—	—	—
3A	Adjustable 0–1800 sec	—	S	S	S	S	S	S	—	S
4	Time Delay Engine Cooldown (TDEC) Fixed 5 min	S	—	—	—	—	—	—	—	—
4A	Adjustable 0–1800 sec	—	S	S	S	S	S	S	—	S
Emergency (S2) Source Sensing										
5H	Phase Reversal Protection	—	S	S	S	0	0	0	—	0
5J	All Phase Undervoltage/Underfrequency	S	S	S	S	S	S	S	—	S
5K	All Phase Overvoltage/Overfrequency	—	S	S	S	S	S	S	—	S
5L	All Phase Voltage Unbalance and Phase Loss	—	—	—	—	0	0	0	—	0
5L	All Phase Voltage Unbalance	—	S	S	S	—	—	—	—	—
System or Engine Test										
6B	Engine Test Pushbutton	S	S	S	S	S	S	S	—	S
6H	Maintained 4-Position Test Switch	—	—	—	—	0	0	0	—	0
7	Time Delay Emergency Fail (TDEF) Fixed 6 sec	S	—	—	—	—	—	—	—	—
7A	Adjustable 0–6 sec	—	S	S	S	S	S	S	—	S
Pushbutton Bypass										
8C	Bypass TDEN	—	S	S	S	S	S	S	—	S
8D	Bypass TDNE	—	S	S	S	S	S	S	—	S
Maintenance Selector Switch										
9B	Electrical Operator Isolator Switch	—	0	0	0	0	0	0	—	0
Preferred Source Selector										
10B	Utility to Utility or Utility to Generator	—	—	—	—	S	S	S	—	S
10D	Generator to Generator	—	—	—	—	S	S	S	—	S
Indicating Lights/LEDs										
12C	Normal (S1) Source Connected	S	S	S	S	S	S	S	S	S
12D	Emergency (S2) Source Connected	S	S	S	S	S	S	S	S	S
12G	Normal (S1) Source Available	S	S	S	S	S	S	S	S	S
12H	Emergency (S2) Source Available	S	S	S	S	S	S	S	S	S
Source Available Contacts										
14C	Normal (S1) Source Available 4 Form C	—	0	0	0	0	0	0	0	0
14D	Emergency (S2) Source Available 4 Form C	—	0	0	0	0	0	0	0	0
14E	Normal (S1) Source Available 1 Form C	—	—	—	—	S	S	S	—	S
14F	Emergency (S2) Source Available 1 Form C	—	—	—	—	S	S	S	—	S
14G	Normal (S1) Source Available 2 Form C	S	S	S	S	0	0	0	S	0
14H	Emergency (S2) Source Available 2 Form C	S	S	S	S	0	0	0	S	0
Position Contacts										
15E	Normal (S1) Source Position 1 Form C	S	S	S	S	S	S	S	S	S
15F	Emergency (S2) Source Position 1 Form C	S	S	S	S	S	S	S	S	S
15G	Normal (S1) Source Position 3 Form C	0	0	0	0	0	0	0	0	0
15H	Emergency (S2) Source Position 3 Form C	0	0	0	0	0	0	0	0	0

Feature	Device Type									
	ATC1	ATC3			ATC8			NTCE		CTC8
	C2	C2	C3	C5	C2	C3	C5	C2	C3	C3
Metering (Specify Normal (S1), Emergency (S2) or Load Side for 18A thru E)										
18A	IQ 250/260	0	0	0	0	0	0	0	0	0
18D	IQ 130/140/150	0	0	0	0	0	0	0	0	0
18E	PXM 2250/2260/2270	0	0	0	0	0	0	0	0	0
18O	IQ Analyzer Normal (S1)	—	0	0	0	0	0	0	0	0
18P	IQ Analyzer Emergency (S2)	—	0	0	0	0	0	0	0	0
18Q	IQ Analyzer Switch Selectable (S1) and (S2)	—	0	0	0	0	0	0	0	0
18V	IQ Analyzer Load Side	—	0	0	0	0	0	0	0	0
18R	DP-4000 Normal (S1)	—	0	0	0	0	0	0	0	0
18S	DP-4000 Emergency (S2)	—	0	0	0	0	0	0	0	0
18T	DP-4000 Switch Selectable (S1) and (S2)	—	0	0	0	0	0	0	0	0
18U	DP-4000 Load Side	—	0	0	0	0	0	0	0	0
18W	Load Side Ammeter (one per phase)	0	0	0	0	—	—	—	—	—
Plant Exerciser										
23A	Selectable—Disabled/7-, 14-, 28-day Interval, FIXED 15 Min Load/No Load, with Failsafe	S	—	—	—	—	—	—	—	—
23J	Selectable—Disabled/7-day Interval, 0–600 Min Load/No Load, with Failsafe	—	—	—	—	S	S	S	—	S
23k	Selectable—Disabled/7-, 14-, 28-day Interval, 0–600 Min Load/No Load, with Failsafe	—	S	S	S	—	—	—	—	—
23L	24 Hour, 7 Day, 365 Day Programmable Plant Exciser	—	0	0	0	0	0	0	—	0
Normal (S1) Source Sensing										
26D	Go to Emergency (S2) Input	—	S	S	S	S	S	S	—	S
26H	Phase Reversal Protection	—	S	S	S	0	0	0	—	0
26J	All Phase Undervoltage/Underfrequency	—	S	S	S	S	S	S	—	S
26K	All Phase Overvoltage/Overfrequency	—	S	S	S	S	S	S	—	S
26L	All Phase Voltage Unbalance and Phase Loss	—	—	—	—	0	0	0	—	0
26L	All Phase Voltage Unbalance	—	S	S	S	—	—	—	—	—
26M	Allows Operation with Generator with Utility Sensing (Available only through a field-installed kit) (not in IES)	0	—	—	—	—	—	—	—	—
26P	All Phase Undervoltage	S	—	—	—	—	—	—	—	—
Alternative Transfer Modes of Operation										
29G	Selector Switch for Auto or Non-Auto Operation	—	0	0	0	0	0	0	—	0
29J	Manual (Pushbutton) Transfer E to N; Automatic N to E	—	0	0	0	0	0	0	—	0
Delayed Transfer Operation Modes										
32A	Time Delay Neutral Adjustable 0–120 sec (delayed transition)	—	—	S	—	—	S	—	—	—
32B	Load Voltage Decay Adj. 2–30% Nominal Voltage	—	—	—	—	—	0	—	—	—
32C	In-Phase Transition Defaults to Load Voltage Decay	—	—	—	—	—	—	—	—	—
32D	In-Phase Transition Defaults to Time Delay Neutral	—	—	—	S	—	—	S	—	—
32F	In-Phase Transition	S	S	—	—	S	—	—	—	—
Logic Extender Cable (Open Enclosures Only)										
34A	48 inches (1219 mm)	—	—	—	—	—	—	—	—	—
34C	96 inches (2438 mm)	0	0	0	0	0	0	0	0	—
35A	Pretransfer Signal Contacts 1 Form C	—	S	S	S	0	0	0	—	0
36	Load Shed from Emergency (S2 Inhibit)	—	—	S	S	—	S	S	—	S
37	Go to "Isolated" Position (not SE Rated)	—	—	—	—	—	0	0	—	0

Feature	Device Type									
	ATC1	ATC3			ATC8			NTCE		CTC8
	C2	C2	C3	C5	C2	C3	C5	C2	C3	C3
Stainless Steel Device Covers										
38A	SS Cover for Device Plate or SE Disconnect	—	0	0	0	0	0	0	0	0
38B	SS Cover for Controller	0	0	0	0	0	0	—	—	0
Space Heater with Thermostat										
41A	100 Watts	0	0	0	0	0	0	0	0	0
42	IBC/CBC Seismic Qualified	S	S	S	S	S	S	S	S	S
Load Sequencing Contacts										
45A	Load Sequencing Contacts (1)	—	—	—	—	0	0	0	—	0
45B	Load Sequencing Contacts (2)	—	—	—	—	0	0	0	—	0
45C	Load Sequencing Contacts (3)	—	—	—	—	0	0	0	—	0
45D	Load Sequencing Contacts (4)	—	—	—	—	0	0	0	—	0
45E	Load Sequencing Contacts (5)	—	—	—	—	0	0	0	—	0
45F	Load Sequencing Contacts (6)	—	—	—	—	0	0	0	—	0
45G	Load Sequencing Contacts (7)	—	—	—	—	0	0	0	—	0
45H	Load Sequencing Contacts (8)	—	—	—	—	0	0	0	—	0
45I	Load Sequencing Contacts (9)	—	—	—	—	0	0	0	—	0
45J	Load Sequencing Contacts (10)	—	—	—	—	0	0	0	—	0
Closed Transition Operational Modes (User Must Specify)										
47D	Closed Transition	—	—	—	—	—	—	—	—	0
47F	Closed Transition Load Voltage Decay	—	—	—	—	—	—	—	—	0
47G	Closed Transition Time Delay Neutral	—	—	—	—	—	—	—	—	0
47H	Parallel Limit Timer	—	—	—	—	—	—	—	—	S
Communications										
48A	INCOM—IPONI Module	—	—	—	—	0	0	0	—	0
48D	ETHERNET—PXG400 Gateway (includes Modbus)	—	0	0	0	0	0	0	—	0
48F	MODBUS—MPONI Module (PONI not required w/ATC-300+)	—	0	0	0	0	0	0	—	0
48P	Power Supply for Remote Annunciator	—	0	0	0	0	0	0	—	0
48RAC	Remote Annunciator w/Control (Includes Modbus)	—	0	0	0	0	0	0	—	0
48MRAC	Remote Annunciator w/Control Multi-Switch (includes Modbus)	—	0	0	0	—	—	—	—	—
48R	Remote Annunciator	—	—	—	—	0	0	0	—	0
49B	Sensing Isolation Transformer	—	0	0	0	0	0	0	—	0
49C	Multi-tap Voltage Transformer (non AG only)	S	S	S	S	S	S	S	S	S
TVSS up to 480V (Connected to Normal)										
51D1	50 kA—CVX	—	0	0	0	0	0	0	0	0
51F1	100 kA—CVX	—	0	0	0	0	0	0	0	0
54B	Upgrade to 316 Stainless Steel	—	0	0	0	0	0	0	0	—
60	Control Power Transformer (240/120V single-phase and 208V only)	0	0	—	—	—	—	—	—	—
80A	Emergency (S2) Inhibit Contact	—	—	0	0	—	0	0	—	0
81A	General Alarm Indication Contact	—	0	0	0	0	0	0	—	0

Feature description

Timers

1. Time Delay Normal to Emergency (TDNE)

Provides a time delay to allow for the generator to warm up before transferring the load to the emergency source. Timing begins only after the emergency source becomes available and is deemed good based on the programmable voltage and frequency set points in the controller.

2. Time Delay Engine Start (TDES)

Provides a time delay before initiating the generator start cycle. This is to account for momentary power outages or voltage fluctuations of the normal source. Provides a Form C contact to the generator starter circuit.

3. Time Delay Emergency to Normal (TDEN)

Provides a time delay of the re-transfer operation to permit stabilization of the normal source. Timing begins only after the normal source becomes available and is deemed good based on the programmable voltage and frequency set points in the controller. This function is fail-safe protected.

4. Time Delay Engine Cooldown (TDEC)

Provides a time delay before initiating the generator stop cycle after the re-transfer operation. This allows the generator to cool down by running unloaded. Timing begins on completion of the re-transfer cycle.

Source 2 sensing

5. Source 2—Monitoring and Protection

Provides monitoring and protection based on the Source 2 voltage and/or frequency set points. All Feature 5 monitoring and protection functions are fail-safe operations.

5J. All-Phase Undervoltage/Underfrequency Protection

Provides undervoltage/underfrequency monitoring and protection based on programmable set points in the controller.

5K. All-Phase Overvoltage/Overfrequency Protection

Provides overvoltage/overfrequency monitoring and protection based on programmable set points in the controller.

5H. Three-Phase Rotation Protection

Provides three-phase reversal sensing in order to protect against transferring to an out-of-phase source. The controller will treat the opposite source as unavailable if the sources are out of phase, based on programmable set points in the controller.

5L. Three-Phase Voltage Unbalance/Phase Loss

Provides phase loss detection from blown fuses on the Source 2 supply circuit.

6B. Test Operators

Automatic transfer switches are provided with a controller faceplate test pushbutton that simulates a loss of the Source 1 as standard. All programmed time delays (TDNE, TDEN, etc.) will be performed as part of the test. Engine run time of the test is equal to the plant exerciser programmed set point. All tests are fail-safe protected.

6H. 4-Position Test Selector Switch (FPSS)

Provides a door-mounted, four-position, maintained contact selector switch marked "Auto," "Test," "Engine Start," and "Off." The FPSS is fail-safe protected, except for the "Off" position. Transfer switch operation is determined by the switch position. Transfer switch operations are as follows:

"Auto"—Automatic operation mode.

"Test"—A load test is performed until the switch is moved to another position.

"Engine Start"—A no-load test is performed until the switch is moved to another position.

"Off"—The automatic transfer controller and engine start contact are disabled. A white pilot light is provided to indicate that the FPSS is in the "Off" position.

7. Time Delay Emergency Fail (TDEF)

Provides a time delay that prevents a connected emergency source from being declared "unavailable" based on the customer's set points. This is to account for momentary generator fluctuations. If the Source 2 remains in a failed state, then 0.5 second after the TDEF timer expires, the transfer switch will proceed with the programmed sequence for re-transfer if Source 1 is available. This time delay is only implemented when Source 2 is a generator.

Note: This feature is also enabled when large loads cause generator output to drop below customer set points.

8. Time Delay Bypass Pushbutton

Provides a momentary contact pushbutton to bypass the TDNE (Feature 1) and/or TDEN (Feature 3) time delays. The Time Delay Bypass Pushbutton contact, when closed, will reduce any or all of the programmed time delay to zero. Must be executed when TDNE or TDEN timer is displayed on the controller.

8C. Bypass Time Delay Emergency to Normal (TDEN)

8D. Bypass Time Delay Normal to Emergency (TDNE)

9B. Maintenance Selector Switch (MSS)

Provides a two-position, maintained contact selector switch marked "Operate" and "Disable." When the MSS is placed in the "Disable" position, the controller logic will be disconnected from the transfer motor circuit. The MSS is placed in the "Operate" position for normal automatic operation.

10. Preferred Source Selector

Provides a means to designate either Source 1 or Source 2 as the "Preferred" source. The "Preferred" source is the source that the transfer switch will connect the load to if it is available.

Note: This is a programmable software feature, not an actual switch.

10B. Preferred Source Selector

Provides a programmable source selector for use on systems composed of dual utility or utility and engine/generator power sources.

10D. Preferred Source Selector

Provides a programmable source selector for use on systems composed of dual engine/generator power sources. (Dual engine starting circuits are provided.)

12C. Source 1—Load Connected

Provides a green indication that indicates the load is connected to Source 1 when lit.

12D. Source 2—Load Connected

Provides a red indication that indicates the load is connected to Source 2 when lit.

12G. Source 1—Present

Provides a white or amber indication “Depending on the Controller” that Source 1 has power; however, this does not indicate whether Source 1 is acceptable.

12H. Source 2—Present

Provides an amber indication that Source 2 has power; however, this does not indicate whether Source 2 is acceptable.

14. Relay Auxiliary Contacts

14C. Source 1 Present

Provides four Form C relay auxiliary contacts. The relay is energized when Source 1 is present.

14D. Source 2 Present

Provides four Form C relay auxiliary contacts. The relay is energized when Source 2 is present.

14E. Source 1 Available

Provides one Form C relay auxiliary contact. The relay is energized when Source 1 is available and within the controller’s programmable set points.

14F. Source 2 Available

Provides one Form C relay auxiliary contact. The relay is energized when Source 2 is available and within the controller’s programmable set points.

14G. Source 1 Present

Provides two Form C relay auxiliary contacts. The relay is energized when Source 1 is present.

14H. Source 2 Present

Provides two Form C relay auxiliary contacts. The relay is energized when Source 2 is present.

15. Switch Position Indication Contact

Provides a contact that indicates if the power switching device is in the “open” or “closed” position.

Note: Option 14c, d, g, and h used with the ATC-300+ controller represent source present, not source available as per the programmed voltage and frequency set points. A source is defined as “present” when the source voltage is capable of energizing the corresponding source present relay coil.

15E. Source 1 Position Indication Contact

Provides one Form C contact that indicates the position of the Source 1 power switching device.

15F. Source 2 Position Indication Contact

Provides one Form C contact that indicates the position of the Source 2 power switching device.

15G. Source 1 Position Indication Contacts

Provides three Form C contacts that indicate the position of the Source 1 power switching device.

15H. Source 2 Position Indication Contacts

Provides three Form C contacts that indicate the position of the Source 2 power switching device.

18. Metering

The ATS controller provides voltage and frequency readings. If additional metering functions are required, Eaton offers a series of digital meters that may be added to the ATS. The meter type can provide simple current and voltage readings or more capable meters providing Power, Demand, and energy readings.

Available with an optional communications interface. (See **Feature 48**—Communications for available communication modules.)

Feature 18 metering options include all required external devices (CTs, etc.) for a fully functioning metering system.

IQ 130/140/150

IQ 130

This digital meter provides basic current and voltage per phase (L-L, L-N) and min./max. readings (I, V). Optional communication RS-485, Modbus RTU.

IQ 140

In addition to basic current and voltage, will provide frequency, power measurements real, reactive and apparent power, total (W, VAR, VA). Optional communication RS-485, Modbus RTU.

IQ 150

In addition to basic current/voltage/frequency and power readings, will provide Energy Real reactive and apparent (Wh, VAR, Vah). Optional communication RS-485, Modbus RTU.

IQ 250/260

IQ 250

This digital meter provides current per phase and current demand, voltage (L-L, L-N), and frequency. Power, energy, and demand readings. Real, reactive, and apparent power and energy, power factor. RS-485 communications, Modbus RTU, or ASCII. Optional I/O slots available.

IQ 260

In addition to all of the features of the IQ 250, power quality analysis is available with THD voltage and current per phase.

Power Xpert 2000

Provides either a Power Xpert PXM 2250, PXM 2260, or PXM 2270 meter.

Plant Exerciser

23A. Plant Exerciser With Fail-Safe

Provides a means for automatic testing of the engine generator set or standby power system. All programmed time delays in the controller will be performed during plant exerciser operations.

Programmable set points for test intervals are start time, either disabled, daily, 7, 14, or 28 days.

15-minute fixed engine test time.

Test may be performed with or without load transfer. Test may be manually cancelled during the operation. This function is fail-safe protected.

23J. Plant Exerciser (PE) With Fail-Safe

Provides a means for automatic testing of the engine generator set or standby power system. All programmed time delays in the controller will be performed during the plant exerciser operation.

Programmable set points for test interval are start time, either disabled or 7 days, and engine test time.

Test may be performed with or without a load transfer. Test may be manually cancelled during the operation. This is a fail-safe operation.

23K. Plant Exerciser With Fail-Safe

Provides a means for automatic testing of the engine generator set or standby power system. All programmed time delays in the controller will be performed during plant exerciser operations.

Programmable set points for test intervals are start time, either disabled, daily, 7, 14, or 28 days, engine test time.

Test may be performed with or without load transfer. Test may be manually cancelled during the operation. This function is fail-safe protected.

26D. Go to Emergency (Source 2)

Provides the capability for an external contact closure to initiate a transfer to the Source 2 power source. This includes starting the generator, performing the programmed time delays, and the transfer operation. Re-transfer will occur when the external contact is opened. This is a fail-safe function.

Source 1 Sensing

26. Source 1—Monitoring and Protection

Provides Source 1 monitoring and protection functions. If Source 1 fails, then the automatic transfer controller will begin the sequence of operations necessary to transfer the load to Source 2. All **Feature 26** monitoring and protection functions are fail-safe operations.

26H. Three-Phase Rotation Protection

Provides three-phase reversal sensing in order to protect against transferring to an out-of-phase source. The controller will treat the opposite source as unavailable if the sources are out of phase, based on programmable set points in the controller.

26J. All-Phase Undervoltage/Underfrequency Protection

Provides all-phase undervoltage/underfrequency monitoring and protection based on programmable set points in the controller.

26K. All-Phase Overvoltage/Overfrequency Protection

Provides all-phase overvoltage/overfrequency monitoring and protection based on programmable set points in the controller.

26L. Three-Phase Voltage Unbalance/ Phase Loss

Provides phase loss detection from blown fuses on the Source 1.

26M. Generator Utility Sensing

Allows for the switch to operate with generators that have internal utility sensing. This option comes as a kit that needs to be field installed.

26N. All-Phase Undervoltage Protection

Provides undervoltage protection for Source 1 (ATC-100 Controller only).

29. Transfer Operation Modes

Provides standard or optional transfer modes, mode selection devices, and operational methods for transfer switches.

29J. Automatic Transfer or Automatic Transfer With Non-Automatic Re-transfer Operation

Provides a field-selectable programmable set point that permits the transfer switch to operate in one of the following two transfer modes (A or B):

- A. Fully automatic operation.
- B. Automatic engine/generator startup and automatic transfer operation from Source 1 to Source 2. Manual pushbutton operation is required to initiate the re-transfer operation and engine/generator shutdown. The pushbutton for manual re-transfer operation is included. This is fail-safe protected.

29G. Automatic/Manual Operation With Selector Switch

Provides two-position selector switch (labeled Auto/manual) that permits selection of the automatic or manual transfer. When in the "Auto" position, the transfer switch operates with fully automatic transfer, re-transfer, and generator startup and shutdown operations. When in the "Manual" position, manual operation is required to initiate the generator startup or re-transfer with generator shutdown operations.

32. Delayed Transition Transfer Modes for Open Transition Transfer Switches

Provides delayed transition transfer modes for an open transition transfer switch. Often used in systems with inductive loads, a delayed transition transfer switch may prevent or reduce inrush currents due to out-of-phase switching of inductive loads.

32A. Time Delay Neutral

Provides a time delay in the neutral position during the transfer and re-transfer operations during which both Source 1 and Source 2 are disconnected from the load circuit. This allows inductive loads time to reach a safe voltage and eliminate back EMF. The time delay is programmable and is the same for both transfer and re-transfer operations. This is a passive feature that requires the consulting engineer/installer to determine the settings based on how the user will operate the facility. Adjustable 0–120 seconds.

32B. Load Voltage Decay

Provides load voltage measurement to sense back EMF that is generated when the transfer switch is the neutral position. It provides a delay in transfer in either direction if an unacceptable level is sensed as established by a programmed set point. This is an active feature that adapts to how the facility is operating in order to minimize neutral position wait time, but ensure safety. Adjustable 2–30% of nominal voltage.

32D. In-Phase Transition With Default to Time Delay Neutral

Provides in-phase transition, which is a feature that will permit a transfer or re-transfer only between two available sources that have a phase angle difference near zero. The in-phase transition feature includes permissible frequency difference and synchronization time set points. In the event Source 1 and Source 2 fail to synchronize within the permitted frequency difference and time, then the controller defaults to the time delay neutral operation as described in **Feature 32A**. Adjustable frequency difference 0.0–3.0 Hz. Adjustable synchronization time allowance 1–60 minutes.

32E. Delayed Transition

The transfer and re-transfer operations during which both Source 1 and Source 2 are disconnected from the load circuit. The time delay is programmable and the same for both transfer and re-transfer operation. Adjustable 3–60 seconds.

32F. In-Phase Transition

Provides in-phase transition, this feature will permit a transfer or re-transfer between two available sources that have a phase angle difference of 8 degrees or less. The in-phase transition feature includes permissible frequency difference and synchronization time set points. In the event Source 1 and Source 2 fail to synchronize within the permitted frequency difference and time, the Alarm relay will energize and "Failed to Sync" will be displayed on Line 1 of the controller. After resetting the alarm, another in-phase transition may be attempted or a non-synchronized transfer may be initiated by failing the connected source. The adjustable frequency difference is 0.0 to 3.0 Hz. If the synchronization does not occur within a specified amount of time, the Alarm relay will energize and the failure will be logged into the transfer history as either "Sync Fail - Freq" or "Sync Fail - Phase" depending on whether the frequency difference or the phase difference was excessive.

Logic Extender Cable**34A. 48 Inches (1219 mm)**

Provides logic extension cable with connectors.

34C. 96 Inches (2438 mm)

Provides logic extension cable with connectors.

35A. Pretransfer Signal With 1 Form C Contact

Provides a signal prior to the transferring of the load. Will not transfer until the programmable delay set point in the controller is reached. If both sources are not available, this option will ignore the time delay set in the controller.

36. Load Shed From Emergency

Provides the capability for an external NC contact to initiate a load circuit disconnection from the Source 2 power source. If the load circuit is connected to Source 2 and the contact is opened, then a re-transfer to Source 1 is completed if Source 1 is available. If Source 1 is not available, then the transfer switch will transfer to neutral. If the load circuit is connected to Source 1 and the contact is open, then a transfer Source 2 is prohibited.

37. Go to Neutral (Not SE Rated)

Provides customer input that can be used to override automatic control and send the ATS to the neutral position.

37A. Service Equipment Rated Transfer Switch

Provides the label "suitable for use as service equipment" and the features necessary to meet the requirements for the label. Includes service disconnect with visible indication and neutral assembly with removable link.

Feature 16B or **16N** must be selected separately.

38. Steel Cover

Provides protection for a device panel as option 38a and protection for the controller as option 38b.

41. Space Heater With Thermostat

Provides a space heater and adjustable thermostat. External control power is not required. Availability is dependent on transfer switch type.

41A. Space Heater With Thermostat— 100 Watt

Provides 100-watt space heater with an adjustable thermostat.

42. Seismic Qualification**45. Load Sequencing Capability**

Provides the capability for sequential closure of up to 10 addressable relays after a transfer. Each addressable relay provides one Form C contact. A single adjustable time delay between each of the relay closures is provided. Operates via a sub-network. Adjustable 1–120 seconds.

45A. Load Sequencing Contact

Provides (1) addressable relay.

45B. Load Sequencing Contact

Provides (2) addressable relays.

45C. Load Sequencing Contact

Provides (3) addressable relays.

45D. Load Sequencing Contact

Provides (4) addressable relays.

45E. Load Sequencing Contact

Provides (5) addressable relays.

45F. Load Sequencing Contact

Provides (6) addressable relays.

45G. Load Sequencing Contact

Provides (7) addressable relays.

45H. Load Sequencing Contact

Provides (8) addressable relays.

45L. Load Sequencing Contact

Provides (9) addressable relays.

45J. Load Sequencing Contact

Provides (10) addressable relays.

47. Transfer Modes for Closed Transition Transfer Switches

Provides available transition transfer modes for a closed transition transfer switch. Closed transition is a "make before break" transfer and re-transfer scheme that will parallel (a maximum of 100 ms) Source 1 and Source 2 providing a seamless transfer when both sources are available. The closed transition feature includes permissible voltage difference frequency difference and synchronization time allowance set points. The phase angle difference between the two sources must be near zero for a permitted transfer. These are all programmable set points in the controller.

47D. Closed Transition

Provides a closed transition transfer as the primary transfer mode. Only under a fail-safe condition (i.e., loss of the connected source) will the controller transfer to the alternate source using the load voltage decay operation as described in **Feature 32B**. Adjustable frequency difference 0.0–0.3 Hz. Adjustable voltage difference 1–5% V.

47F. Closed/Load Voltage Decay

ATC-800 controllers equipped with Feature Set 47F will perform a closed transition when both sources are synchronized in frequency, phase, and voltage. Failure to synchronize will result in an open transition Time Delay Load Voltage Decay transfer. Time Delay Load Voltage Decay uses the load voltage measurements to sense back EMF that is generated when the transfer switch is in the Neutral position. It provides a delay in transfer in either direction if an unacceptable level is sensed as established by a customer programmed level. The transfer will not take place until the back EMF decays below the acceptable programmed level. This feature has a separate setting of enabling or disabling the operation. If disabled, the transfer switch will not delay in the Neutral position and will transfer between the sources as fast as possible. This feature is not available with the Time Delay Neutral Optional **Feature 32A**.

47G. Closed/Time Delay Neutral

ATC-800 controllers equipped with Feature Set 47F will perform a closed transition transfer when both sources are synchronized in frequency, phase, and voltage. Failure to synchronize will result in an open transition Time Delay Neutral transfer. Time Delay Neutral provides a time delay in the transfer switch neutral position when both sources are open. This delay takes place when the load is transferred in either direction to prevent excessive in-rush currents due to out-of-phase switching of large motor loads.

48. Communication Modules

Provides communications modules for the ATC-300, ATC-600, and ATC-800 transfer switch controllers.

48A. INCOM**Communication (IPONI)**

Provides Eaton's proprietary INCOM protocol communications modules.

48D. Ethernet

Communication (PXG400 Gateway)

Translates Modbus RTU, QCPort, or INCOM to Modbus TCP. The PXG400 Gateway includes embedded Web server monitoring of up to 64 connected devices. (Includes the IPONI with the ATC-600 and ATC-800 controllers.)

48F. Modbus

Communication (MPONI)

Provides Modbus RTU protocol via communications module.

48R. Remote Annunciator

Provides remote monitoring of source availability, source position, and test status for the ATC-600 and ATC-800 controllers. Operates via the controller sub-network.

48RAC. Remote Annunciator with Control

Provides remote monitoring and control via a color touch screen display for the ATC-300 and ATC-800 controllers. Operates using Modbus protocol (Option 48F required).

48 MRAC. Multiple ATS Remote Annunciator with Control

Provides remote monitoring and control via color touch screen display for four or eight ATC-300+ transfer switches. Operates using Modbus protocol (Option 48F required).

Option 51. Surge Protection Device

Two types of surge protection devices are used in Eaton automatic transfer switches. Both types meet the requirements for UL 1449 3rd Edition for surge suppression devices and are CE marked. The type CVX is used on Eaton wallmount ATS designs, and the Eaton type SPD are used on floorstanding designs.

CVX

The CVX device features a thermally protected metal oxide varistor technology and comes with high-intensity LED phase status indicators.

51D1. 50 kA—CVX

51F1. 100 kA—CVX

Glossary

With respect to their use in this document and as they relate to switch operation, the following terminology is defined:

Available—A source is defined as “available” when it is within its undervoltage/overvoltage/underfrequency/overfrequency (if applicable) set point ranges for the nominal voltage and frequency setting.

Fail-safe—A feature that prevents disconnection from the only available source and will also force a transfer or re-transfer operation to the only available source.

Re-transfer—Re-transfer is defined as a change of the load connection from the secondary to primary source.

Source 1—The primary source or normal source or normal power source or normal. (Except when Source 2 has been designated the “Preferred Source.”)

Source 2—The secondary source or emergency source or emergency power source or emergency or standby or backup source. (Except when Source 2 has been designated the “Preferred Source.”)

Source 1—Failed or fails—Source 1 is defined as “failed” when it is outside of its undervoltage or overvoltage or underfrequency or overfrequency (if applicable) set point ranges for the nominal voltage and frequency setting.

Source 2—Failed or fails—Source 2 is defined as “failed” when it is outside of its undervoltage or overvoltage or under-frequency or overfrequency (if applicable) set point ranges for the nominal voltage and frequency setting for a time exceeding 0.5 seconds after the time delay emergency fail (TDEF) time delay expires.

Transfer—“Transfer” is defined as a change of the load connection from the primary to secondary source except when specifically used as “Transfer to Neutral.”

Transfer to Neutral—“Transfer to Neutral” is defined as when the load circuits are disconnected from both Source 1 and Source 2.

Communications

Optional communication capability via communication gateway is available allowing remote data access, control, programming, system interface, and dispatch.

System interface

A system control panel provides a user-friendly interface to the closed transition soft load controller, allowing operators to easily monitor the switching devices position and manually test generator and the system operations.

Switching devices status lights

- Source 1 open (green)
- Source 1 closed (red)
- Source 1 trip (amber)
- Source 2 open (green)
- Source 2 closed (red)
- Source 2 trip (amber)

Front panel control switches and lights

The combination of the following pilot devices can be implemented on the unit:

- AUTO/TEST switch
- SYSTEM TEST switch
- TEST MODE switch
- ALARM SILENCE switch
- READY FOR OPERATION lamp (white)—verifies the status

Eaton Corporation
Electrical Sector
1111 Superior Avenue
Cleveland, OH 44114 USA
Eaton.com

© 2013 Eaton Corporation
All Rights Reserved
Printed in USA
Publication No. TD01602018E / Z13140
February 2013